



BE-970 vehicle CCTV monitor

User & fitting guide

Manuel d'utilisation

Bedienungsanleitung

Guida all'uso e all'installazione

Instrucciones de empleo

Handleiding



Stock code #3135



1 Contents/Contenu/Inhalt/Contenuti/Contenido/Inhoud

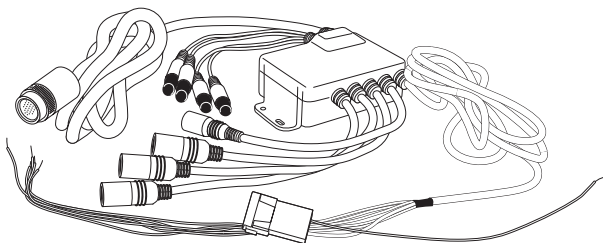
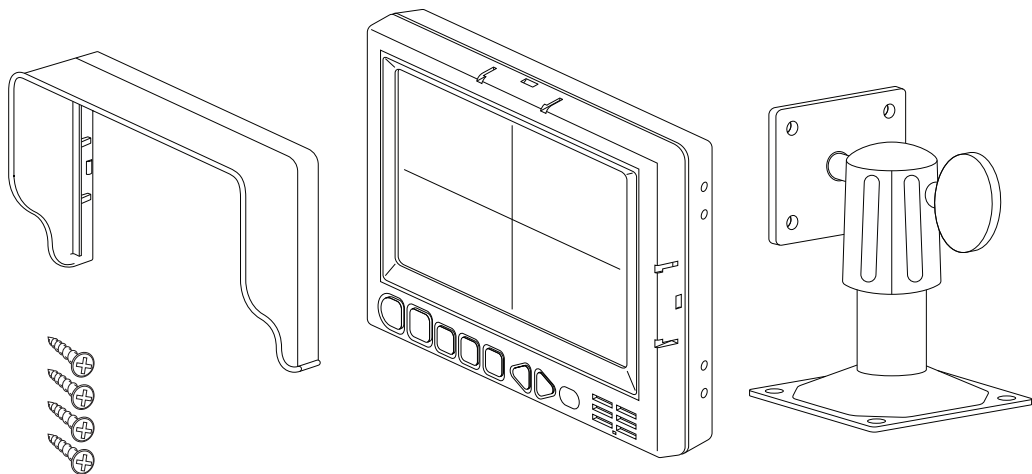

2 Monitor installation/Installation moniteur/ Monitorinstallation/Installazione schermo/Instalación del monitor/ Monitorinstallatie

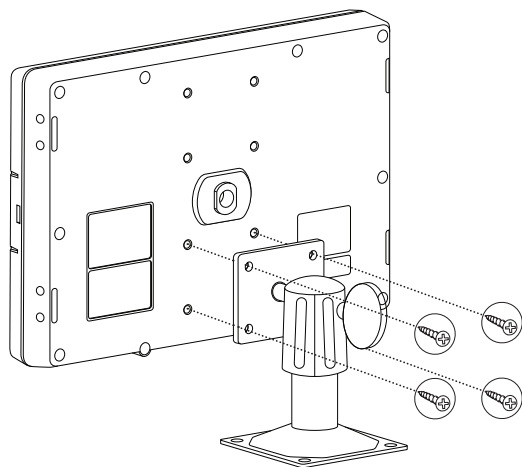

3 Connections/Connexions/Anschlüsse/Connessioni/Conexiones/Aansluitingen

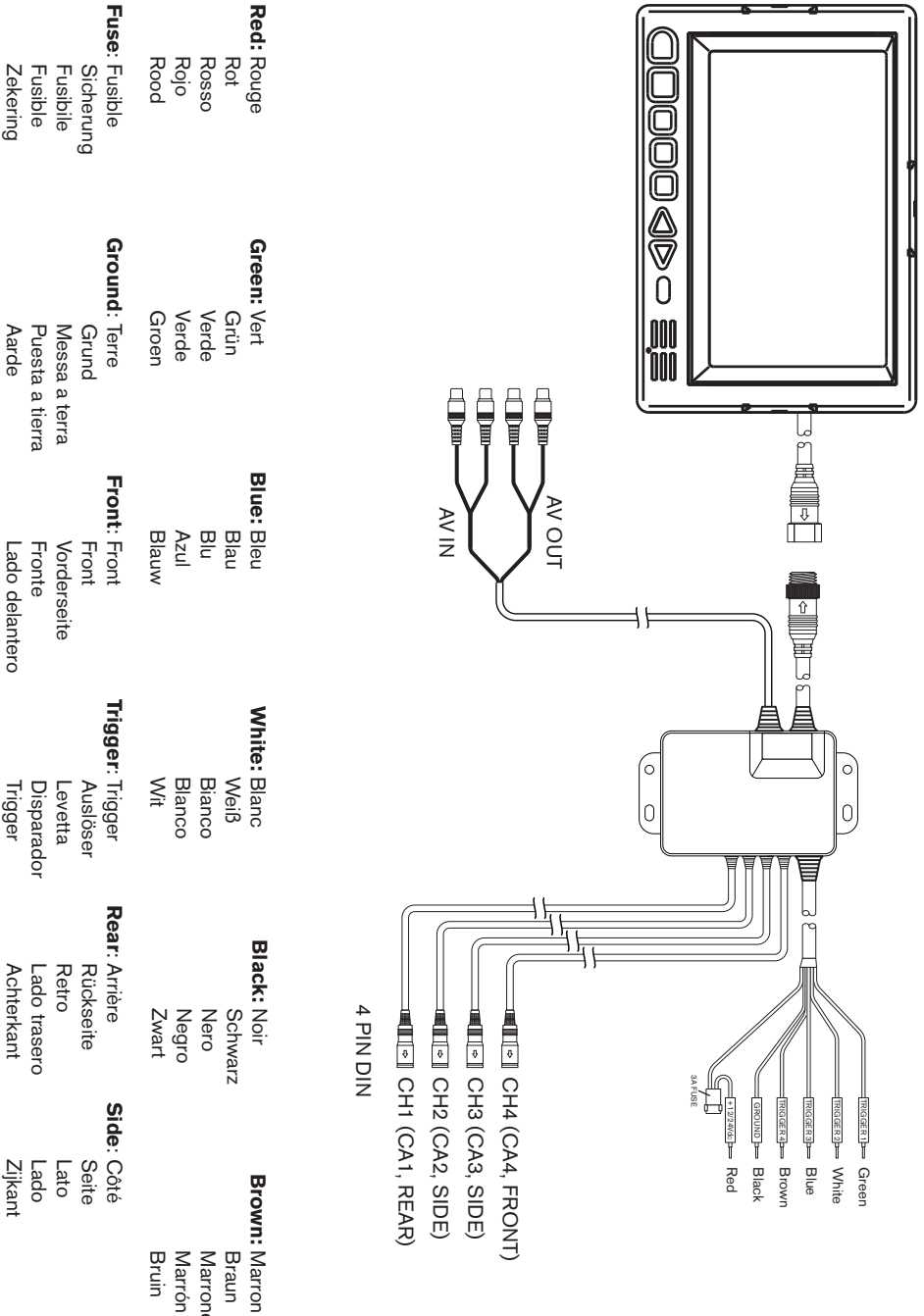

4 Controls/Contrôle/Steuerungen/Comandi/Controles/Besturingen

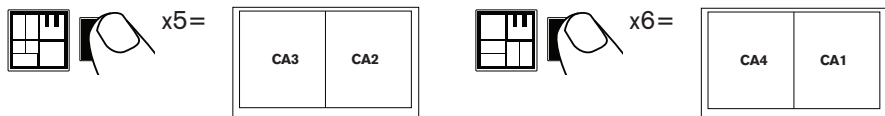
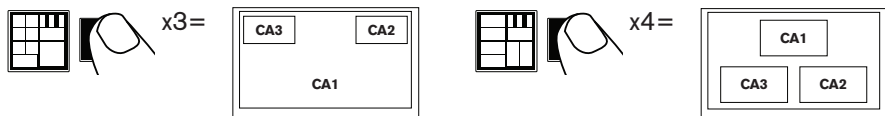
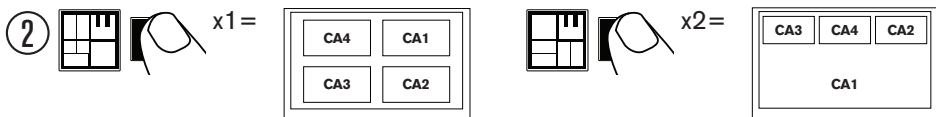
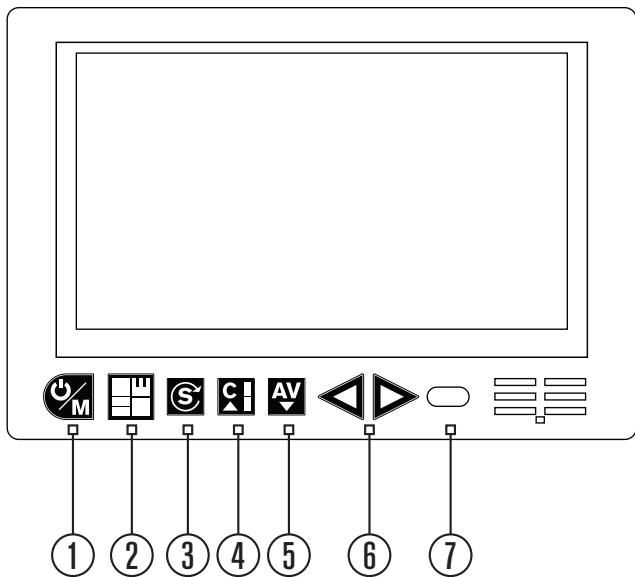

4 Controls/Contrôle/Steuerungen/Comandi/Controles/Besturingen

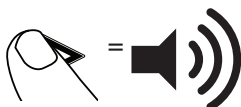
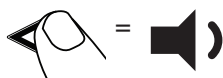
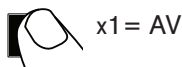
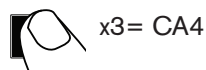
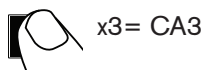
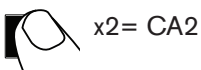
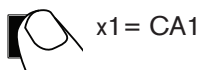
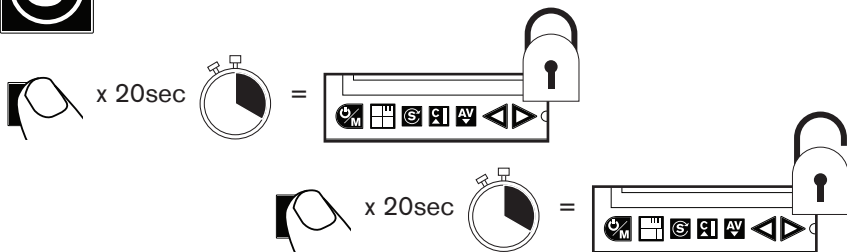
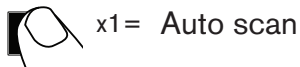

7

Automatic low light sensor - automatically adjusts monitor brightness.

Capteur optique automatique de basse luminosité - Réglage automatique de luminosité du moniteur

Automatischer Low-Light Sensor -passt Monitorhelligkeit automatisch an

Sensore automatico di bassa luminosità – varia automaticamente la luminosità dello schermo

Sensor automático de baja luminosidad – adapta automáticamente la luminosidad del monitor

Automatische low-light sensor – past de helderheid van de monitor automatisch aan

5 When in menu/Lorsque dans le menu/Wenn im Menü/Quando nel menu/Si en el menú/Als in het menu



6 Split display via trigger/Ecran partagé par le trigger/Split Display über Auslösen/Schermo diviso mediante levetta/Pantalla segmentada mediante el disparador/Gesplitst display via trigger

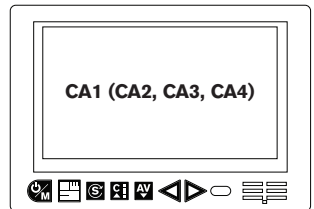
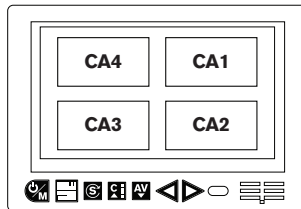
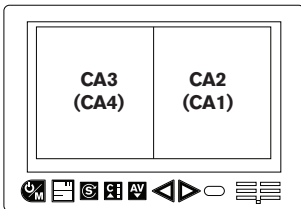
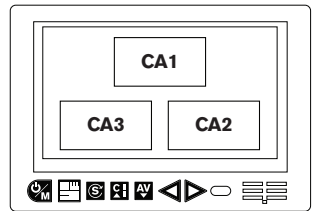
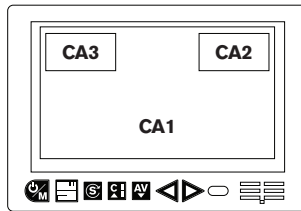
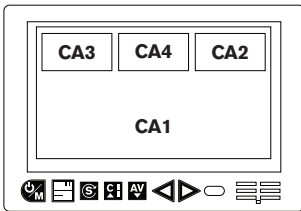

7 Specifications/Spécifications/Spesifikationen/Specifiche/Especificaciones/Specificaties

ENGLISH

Specifications	
Monitor	BE-970FM
TV System	NTSC / PAL
Picture	7" TFT LCD colour monitor with On Screen Display function
Display size	7" diagonal
Field of view	Top: 40°, Bottom: 60°, Left: 60°, Right: 60°
Resolution	(480 x3 (RGB) x 234)
Picture image	Mirror / normal
Power	10 - 32Vdc input
Inputs	1 RCA / 4 CAM
Video input	1.0V p-p, 75 ohm sync negative

FRANCAIS

Spécifications	
Moniteur	BE-970FM
Système TV	NTSC / PAL
Image	7" TFT LCD moniteur couleur avec affichage de fonction (OSD)
Dimension de l'écran	7" diagonal
Champ de vision	Haut: 40°, Bas: 60°, Gauche: 60°, Droite: 60°
Résolution	(480 x3 (RGB) x 234)
Image vidéo	Mirror / normal
Alimentation	10 - 32Vdc input
Entrées	1 RCA / 4 CAM
Entrée video	1.0V p-p, 75 ohm sync negative

DEUTSCH

Specifications	
Monitor	BE-970FM
TV-System	NTSC / PAL
Bild	7" TFT LCD Farbmonitor mit Funktionssanzeige (OSD)
Bildschirmgröße	7" diagonal
Sichtfeld	Oben: 40°, Unten: 60°, Links: 60°, Rechts: 60°
Auflösung	(480 x3 (RGB) x 234)
Videobild	Spiegel / normal
Stromversorgung	10 - 32Vdc input
Eingänge	1 RCA / 4 CAM
Videoeingang	1.0V p-p, 75 ohm sync negative

ITALIANO

Specifiche	
Schermo	BE-970FM
Sistema TV	NTSC / PAL
Immagine	Schermo a colori LCD 7" TFT con visualizzazione su schermo (OSD)
Formato display	7" diagonale
Campo visivo	alto: 40°, basso: 60°, sinistra: 60°, destra: 60°
Risoluzione	(480 x3 (RGB) x 234)
Immagine a video	Mirror / normale
Alimentazione	Corrente continua 10 - 32V
Prese	1 RCA / 4 CAM
Presa video	1.0V p-p, 75 ohm sync negativo

7 Specifications/Spécifications/Spesifikationen/Specifiche/ Especificaciones/Specificaties

ESPAÑOL	
Especificaciones	
Monitor	BE-970FM
Sistema de TV	NTSC / PAL
Imagen	Monitor a color de 7" TFT LCD con visualización de las funciones (OSD)
Tamaño de pantalla	7" diagonal
Campo visual	arriba: 40°, abajo: 60°, a la izquierda: 60°, a la derecha: 60°
Resolución	(480 x3 (RGB) x 234)
Imagen de video	Mirror / normal
Suministro de corriente	10 - 32Vdc input
Entradas	1 RCA / 4 CAM
Entrada de video	1.0V p-p, 75 ohmios sync negativo

NEDERLANDS	
Specificaties	
Monitor	BE-970FM
TV-systeem	NTSC / PAL
Beeld	7" TFT LCD kleurenmonitor met functieaanduiding (OSD)
Displayformaat	7" diagonaal
Gezichtsveld	Boven: 40°, Onder: 60°, Links: 60°, Rechts: 60°
Resolutie	(480 x3 (RGB) x 234)
Videobeeld	Spiegel / normaal
Stroomvoorziening	10 - 32Vdc input
Ingangen	1 RCA / 4 CAM
Videoingang	1.0V p-p, 75 ohm sync negative

Disclaimer

Camera monitor systems are an invaluable driver aid but do not exempt the driver from taking every normal precaution when conducting a manoeuvre. No liability arising out of the use or failure of the product can in any way be attached to Brigade or to the distributor.

Dénégation

Les systèmes de moniteurs des caméras sont une aide précieuse pour le conducteur, mais celui-ci doit toutefois prendre toutes les précautions nécessaires pendant les manœuvres. Brigade ou ses distributeurs n'assument aucune responsabilité résultant de l'utilisation ou d'un défaut du produit.

Verzichterklärung

Die Kamerabildschirmssysteme sind eine wertvolle Hilfe für den Fahrer, entbinden ihn jedoch nicht von der notwendigen Sorgfalt beim Manövrieren des Fahrzeuges. Brigade und seine Vertriebshändler haften nicht für Schäden aus der Nutzung oder einer Fehlfunktion des Produktes.

Disconoscimento

I sistemi di monitor della telecamera sono un aiuto prezioso per il conduttore, ma non lo esonerano dall'obbligo di prendere le precauzioni necessarie durante le manovre del veicolo. Brigade e i suoi distributori non si assumono nessuna responsabilità per danni risultanti dall'utilizzo o da un malfunzionamento del prodotto.

Negante

Los sistemas de pantalla de cámara son una valiosa ayuda destinada a los conductores; en todo caso no les resta la responsabilidad de proceder con precaución a la hora de maniobrar con el vehículo. Brigade y sus distribuidores comerciales no se responsabilizan de los daños derivados de un mal funcionamiento del producto.

Verwerping

De camera-monitorsystemen zijn een waardevolle hulp voor de bestuurder, ontheffen hem echter niet van de nodige zorgvuldigheid bij het manoeuvreren van het voertuig. Brigade en zijn distributeurs zijn niet aansprakelijk voor schade door gebruik of een gebrek van het product.

Serial No:

Stock code:



Head Office

Brigade Electronics plc
Brigade House, The Mills
Station Road, South Darent
DA4 9BD United Kingdom
Tel: +44 (0)1322 420300
Fax: +44 (0)1322 420343
email: sales@brigade-electronics.com

Brigade Electronics Inc
202 Delaware Avenue, Suite 1
Palmerton PA 18071 USA
Tel: +1 (610) 826-7870
Fax: +1 (484) 229-0088
email: infousa@brigade-electronics.com

Brigade Electronique Sarl
22 Rue Pierre Bontemps
72000 Le Mans
France
Tel: +33 (0) 2 23 61 08 97
Fax +33 (0) 2 23 61 08 97
email: info@brigade-electronique.fr

Brigade Elettronica srl
Via V. Alfieri n. 28
50121 - Firenze
Italia
Telefono: +39 (0) 55 24 59 43
email: info-italia@brigade-electronics.com

Brigade Elektronik GmbH
Haberstr. 36 A
24537 Neumünster Germany
Telefon: +49 (0) 4321 555 362
Fax: +49 (0) 4321 555 361
email: info@brigadegmbh.de

